



# OCTOPUS

## DETAIL INSTALLATION GUIDE

REV: A 29 MAY 2008



### OC15SUK12B – TYPE B – MULTI I/O CONNECTION KIT

#### A. SYSTEM OVERVIEW:

1. The Octopus Type B – Multi I/O connection kit can be fitted to mechanical push-pull cable controlled sterndrive power assisted steering cylinders made by Volvo (models noted below) and Mercruiser (DHB). Installation of the kit allows the addition of a second steering cable which can be used for autopilot control when connected to the Octopus Remote Mechanical Drive or Jog control when connected to the Octopus Intellisteer remote Mechanical Drive.
2. Volvo steering cylinder models 3860882 – 3862456 – 3862514 are fitted to Diesel Powered SX drives from 1997. Volvo steering cylinder models 3860726 – 3860883 – 3862210 – 3862513 are fitted to Gasoline Powered SX & DP-S drives from 1997 and newer. Mercruiser DHB steering cylinders are fitted to Alpha One Generation II and Bravo Sterndrives from 1994 and newer.

Note: See separate guide OC15SUK12C – Type C – Multi I/O Connection Kit for – Mercruiser Saginaw Steering Cylinder fitted to Alpha One Generation II and Bravo Sterndrives from 1983 to 1993 and Volvo model 872215 fitted to Diesel powered DP drives from 1994. Steering Cylinders from other Manufactures are not compatible with this system at this time. Consult the factory for additional information.

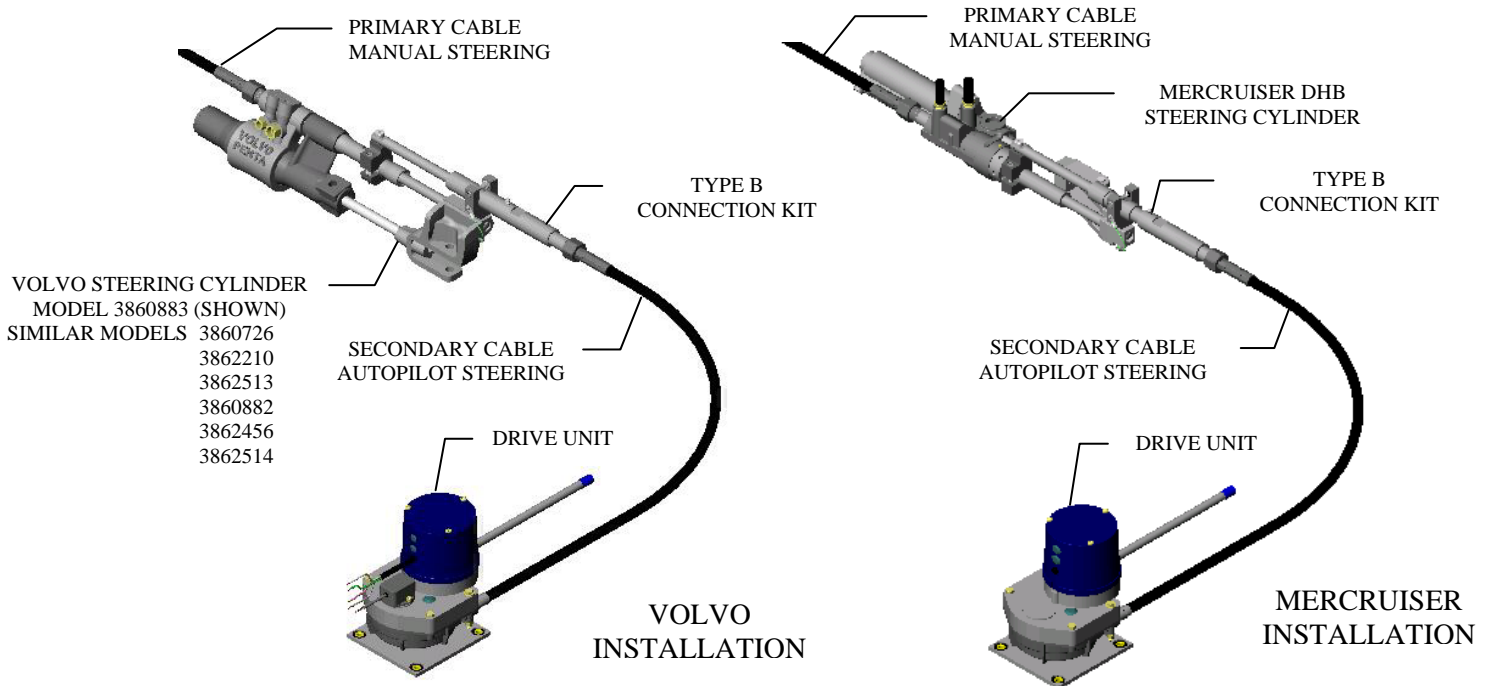

#### B. REQUIRED PARTS:

1. Part # OC15SUK12B - Type B – Multi I/O Connection Kit
2. Part # OC15109-6 secondary steering cable (6 foot standard) – other lengths available (Equivalent Steering Cables manufactured by Morse, Uflex or Teleflex may be used with the addition of cable end adapters. OC15SUK08 for the Uflex M66 or Teleflex SSC62 - OC15SUK07 for the Uflex M47, Teleflex SSC72 or Morse 304415)
3. OCAFMDRERW drive unit (see separate detail installation guide)
4. General Shop Tools

**OCTOPUS PRECISION PRODUCTS - VANCOUVER CANADA**  
**TEL 604 940 2010 - FAX 604 952 2650**

**DETAIL INSTALLATION GUIDE (continued)**  
**OC15SUK12B – TYPE B – MULTI I/O CONNECTION KIT**

**C1. Recommended Installation Procedure For Mercruiser DHB steering Cylinder**

**C1a. Prepare Steering Cylinder**

- i. Using the manual steering helm, extend the steering cylinder to full HO as shown. Note that it may be necessary to run the engine to achieve this.
- ii. Using shop tools, remove the cotter pin and clevis pin connecting the manual steering cable rod end to the steering cylinder clevis bracket.
- iii. Ensure that the position of the flats on the steering cylinder sleeve is vertical. Note that it may be necessary to crack the nut on the manual steering cable to achieve this. If so re-torque the nut to 175 in-lbs (20Nm).

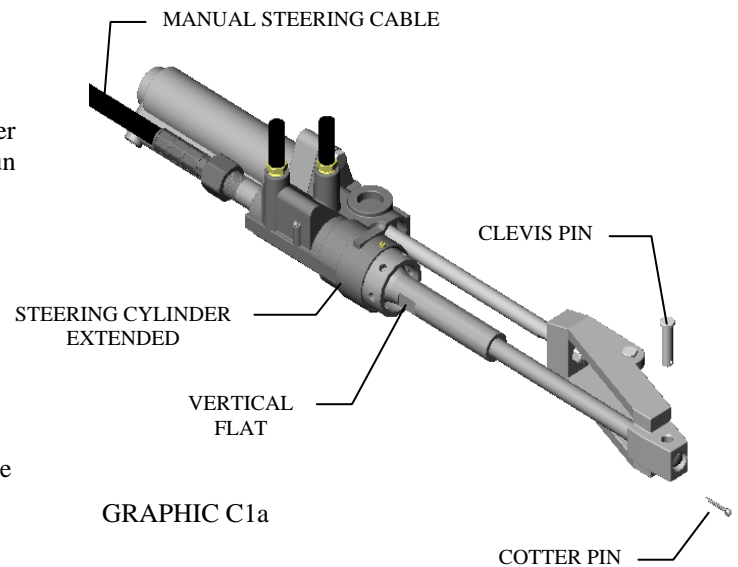

**C1b. Install Drive Collar & Spacer Bush**

- i. Using the manual steering helm, retract the manual steering cable to full HO as shown.
- ii. Loosen the clamp screw and lock nut on the Drive Collar.
- iii. Assemble Spacer Bush onto sleeve of steering cylinder. See graphic for orientation.
- iv. Assemble Drive Collar onto sleeve of steering cylinder and over Spacer Bushing. See graphic for orientation. **DO NOT** tighten clamp screw at this time.
- v. Using the manual steering helm, extend the manual steering cable back to full HO as shown.

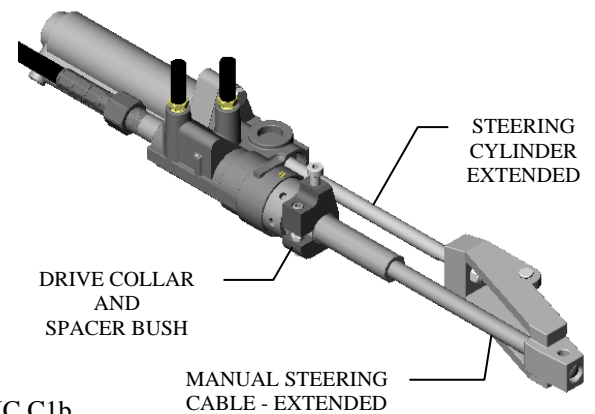
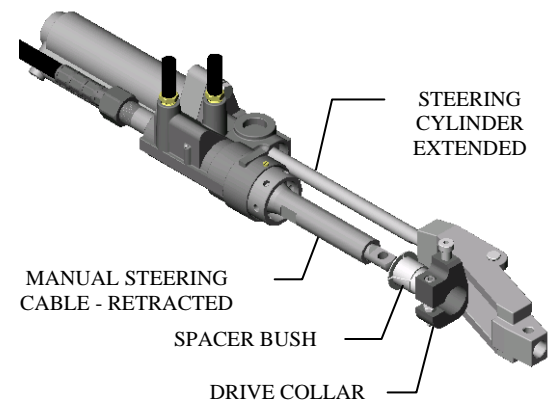

**DETAIL INSTALLATION GUIDE (continued)**  
**OC15SUK12B – TYPE B – MULTI I/O CONNECTION KIT**

C1c. Pre-Assemble Guide Tube to Yolk - (only if required, this step is factory assembled before shipping)

- i. Crack lock nut and remove both clamp screw and lock nut from Yolk.
- ii. Lower Guide Tube into Yolk – engaging Yolk slot onto groove of Guide Tube.
- iii. Insert Clamp Screw into front leg of Yolk and engage Lock Nut – screw into both Lock Nut and rear leg of Yolk.
- iv. Torque Clamp Screw to Yolk to 27 in-lbs (3Nm). Torque Lock Nut to Yolk to 45 in-lbs (5Nm).

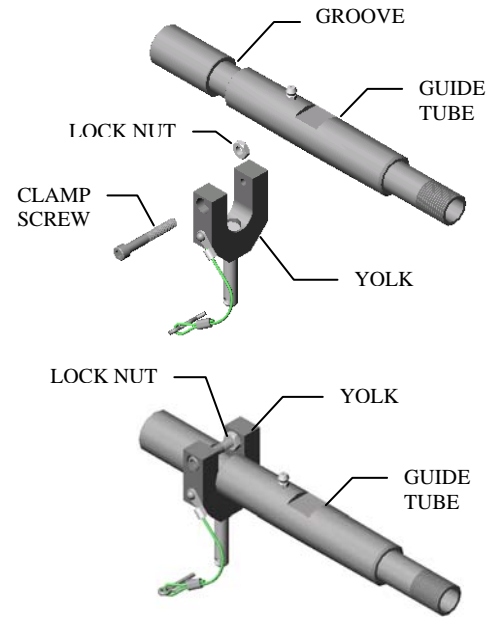

GRAPHIC C1c

C1d. Pre-assemble Secondary Steering Cable to Guide Tube/Yolk

- i. Ensure that both the nut and the male thread are lubricated with marine quality grease before assembly.
- ii. Ensure that the static portion of the rod end and the inside of the guide tube are liberally coated with marine quality grease.
- iii. Insert the rod end portion of the secondary steering cable into the threaded side of the guide tube assembly.
- iv. Engage 7/8-14 UNF nut on male thread, hand tighten and torque to 175 in-lbs (20Nm). Note that the nut has an internal thread locking feature that can increase the effort required to initial hand tighten.

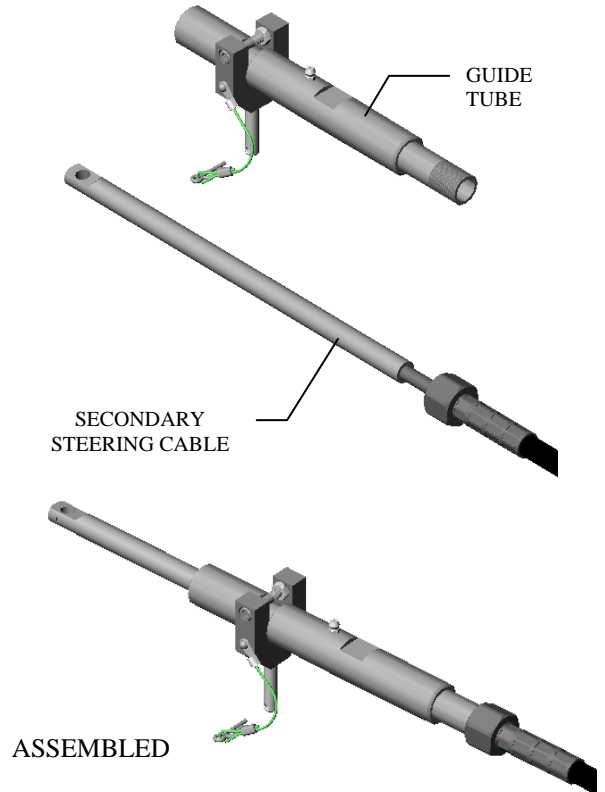

GRAPHIC C1d

**DETAIL INSTALLATION GUIDE (continued)**  
**OC15SUK12B – TYPE B – MULTI I/O CONNECTION KIT**

**C1e. Assemble Connection Kit & Second Steering Cable to Steering Cylinder**

- i. Remove Shoulder Screw from Drive Collar.
- ii. Position Connection Kit & Second Steering Cable above the Steering Cylinder as shown in Stage 1 graphic
- iii. Lower Connection Kit & Second Steering Cable onto Steering Cylinder. Ensure that the clevis pin enters the both the holes in the Steering Cylinder clevis bracket and the manual Steering Cable rod end. Insert Hitch Pin.
- iv. Misalignment may prevent engagement of the new Yolk clevis pin. If so, re-align cross hole in manual Steering Cable rod end with hole in Steering Cylinder clevis bracket by adjusting the manual steering helm slightly.
- v. Adjust the position of the Second Cable rod end and the Drive Collar to align the Shoulder Screw holes. Insert Shoulder Screw – Torque to 55 inlbs (6Nm). Note that the Shoulder Screw has a thread locking feature which increases the torque required for thread running.
- vi. Axially position Drive Collar to set the 0.25 inches gap (see graphic). Torque Clamp Screw to Drive Collar to 175 inlbs (19Nm). Torque Lock Nut to Drive Collar to 45 inlbs (5Nm).
- vii. It is recommended that the drive unit is NOT attached to the Second Steering Cable when performing operation v. & vi. above. If the drive unit is already attached, it will be HARDER to fine adjust the position of the cable rod end. Providing 12v dc power to the clutch and motor circuit may be necessary.

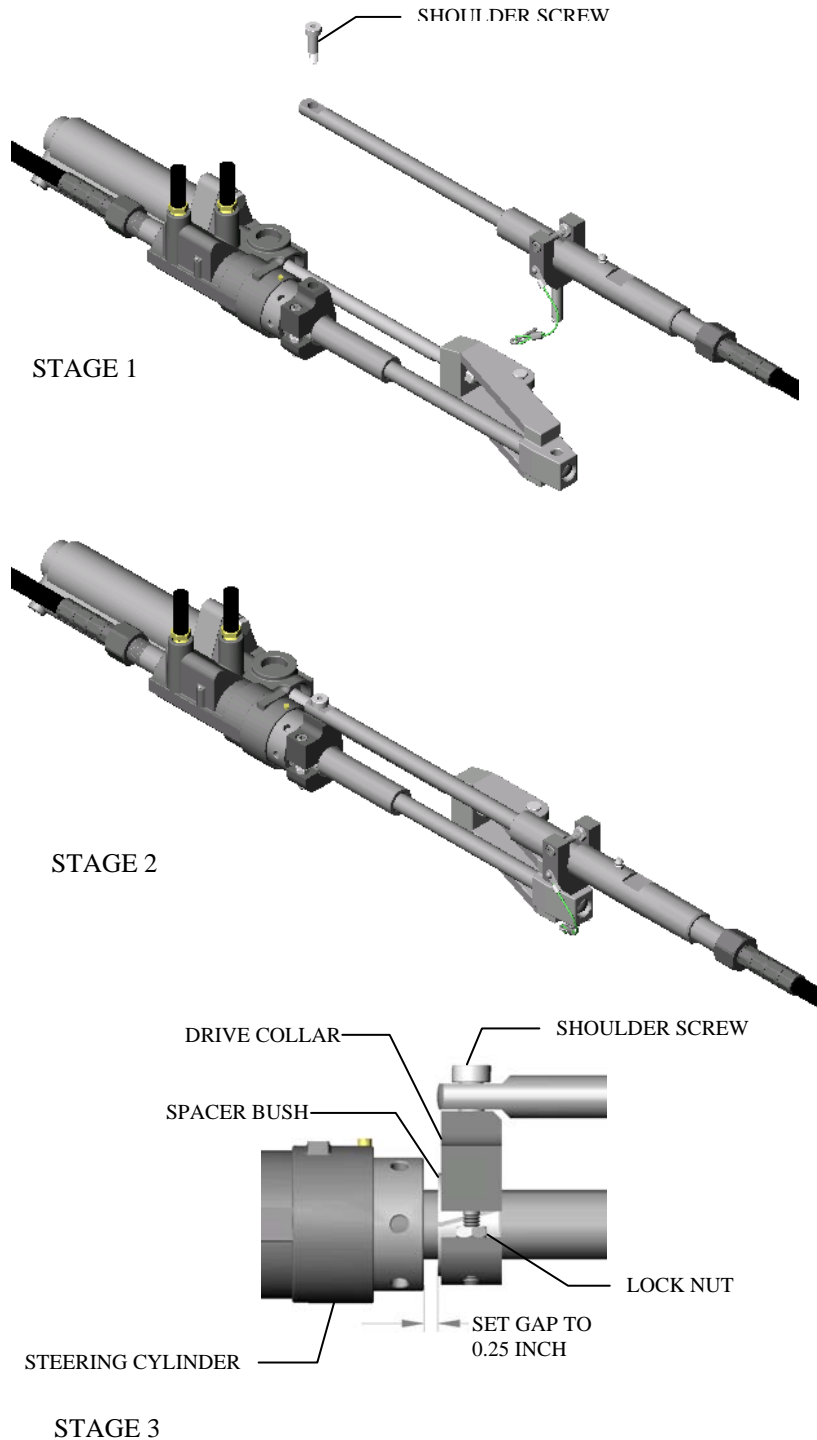

GRAPHIC C1e

**DETAIL INSTALLATION GUIDE (continued)**  
**OC15SUK12B – TYPE B – MULTI I/O CONNECTION KIT**

C1f. Install Drive Unit

- i. See separate Detail Installation Guide for Drive Unit.

C1g. Perform Interference Evaluation (2 people required)

- i. It is extremely important that a steering system **FULL FUNCTION AND OPERATING CLEARANCE CHECK** be performed between the new Connection Kit & Second Steering Cable and **ALL** adjacent hardware including hoses, electrical cables and control cables.
- ii. The drive unit **MUST** be installed with the Second Steering Cable Assembled before performing the Function & Interference Evaluation. Note that the Guide Tube and Steering Cable Outer Jacket (at the Guide Tube end) **DO MOVE** when the steering system is activated.
- iii. With one person operating the manual steering Helm and one person observing the tiller area. Slowly run the tiller to full HO left and then to full HO right while the observer ensures that there are no physical interferences and that the Steering System is functional. Note that it will be necessary to run the engine to perform this operation.
- iv. It may be necessary to re-rout hoses, electrical cables or control cables. **ALL** hardware must be well clear of the new Connection Kit and Second Steering Cable. Note that chaffing can occur if parts are allowed to come into contact.

---

C2. Recommended Installation Procedure For Volvo model 3860883 steering Cylinder (shown)  
Similar for models 3860726 – 3862210 – 3862513 – 3860882 – 3862456 - 3862514

C2a. Prepare Steering Cylinder

- i. Using the manual steering helm, extend the steering cylinder to full HO as shown. Note that it may be necessary to run the engine to achieve this.
- ii. Using shop tools, remove the cotter pin and clevis pin connecting the manual steering cable rod end to the steering cylinder clevis bracket.
- iii. Ensure that the position of the flats on the steering cylinder sleeve is vertical. Note that it may be necessary to crack the nut on the manual steering cable to achieve this. If so re-torque the nut to 175 in-lbs (20Nm).

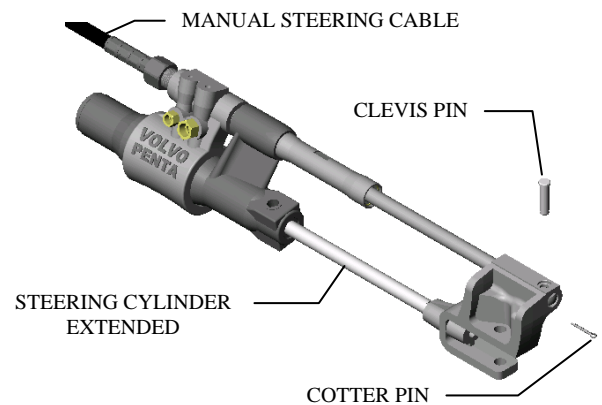

GRAPHIC C2a

**DETAIL INSTALLATION GUIDE (continued)**  
**OC15SUK12B – TYPE B – MULTI I/O CONNECTION KIT**

**C2b. Install Drive Collar & \*Spacer Bush**

- i. Using the manual steering helm, retract the manual steering cable to full HO as shown.
- ii. Loosen the clamp screw and lock nut on the Drive Collar.
- iii. Assemble Spacer Bush onto sleeve of steering cylinder. See graphic for orientation.
- iv. Assemble Drive Collar onto sleeve of steering cylinder and over Spacer Bushing. See graphic for orientation. **DO NOT** tighten clamp screw at this time.
- v. Using the manual steering helm, extend the manual steering cable back to full HO as shown.

\* Note that the Spacer Bush is not required on models 3862513 & 3862514 which are fitted to drives from September 2003. On these models, the drive collar will clamp directly onto the manual steering cable guide tube.

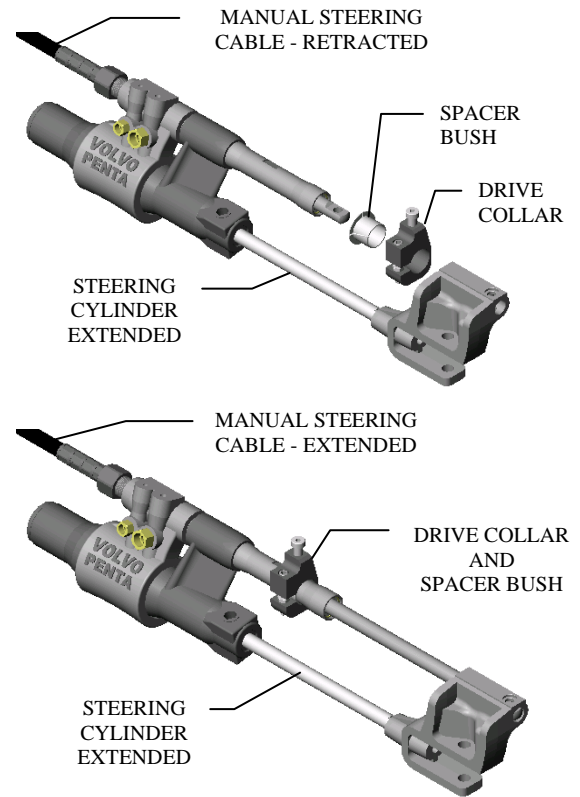

GRAPHIC C2b

**C2c. Pre-Assemble Guide Tube to Yolk - (only if required, this step is factory assembled before shipping)**

- i. Crack lock nut and remove both clamp screw and lock nut from Yolk.
- ii. Lower Guide Tube into Yolk – engaging Yolk slot into groove of Guide Tube.
- iii. Insert Clamp Screw into front leg of Yolk and engage Lock Nut – screw into both Lock Nut and rear leg of Yolk.
- iv. Torque Clamp Screw to Yolk to 27 in-lbs (3Nm). Torque Lock Nut to Yolk to 45 in-lbs (5Nm).

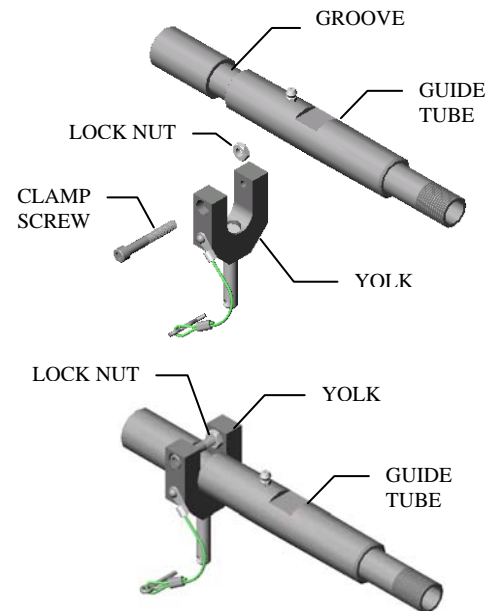

GRAPHIC C2c

**DETAIL INSTALLATION GUIDE (continued)**  
**OC15SUK12B – TYPE B – MULTI I/O CONNECTION KIT**

**C2d. Pre-assemble Secondary Steering Cable to Guide Tube/Yolk**

- i. Ensure that both the nut and the male thread are lubricated with marine quality grease before assembly.
- ii. Ensure that the static portion of the rod end and the inside of the guide tube are liberally coated with marine quality grease.
- iii. Insert the rod end portion of the secondary steering cable into the threaded side of the guide tube assembly.
- iv. Engage 7/8-14 UNF nut on male thread, hand tighten and torque to 175 in-lbs (20Nm). Note that the nut has an internal thread locking feature that can increase the effort required to initial hand tighten.

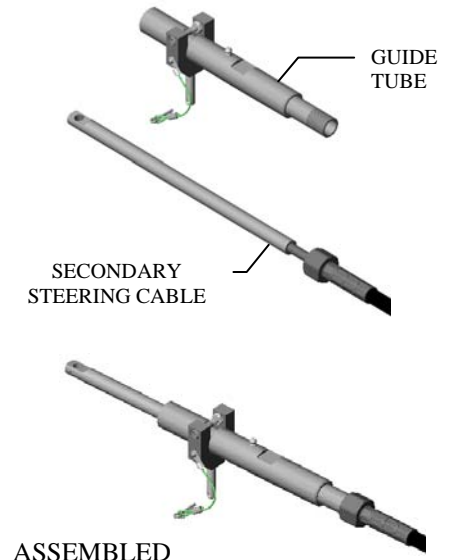

GRAPHIC C2d

**C2e. Assemble Connection Kit & Second Steering Cable to Steering Cylinder**

- i. Remove Shoulder Screw from Drive Collar.
- ii. Position Connection Kit & Second Steering Cable above the Steering Cylinder as shown in Stage 1 graphic
- iii. Lower Connection Kit & Second Steering Cable onto Steering Cylinder. Ensure that the clevis pin enters the both the holes in the Steering Cylinder clevis bracket and the manual Steering Cable rod end. Insert Hitch Pin.
- iv. Misalignment may prevent engagement of the new Yolk clevis pin. If so, re-align cross hole in manual Steering Cable rod end with hole in Steering Cylinder clevis bracket by adjusting the manual steering helm slightly.
- v. Adjust the position of the Second Cable rod end and the Drive Collar to align the Shoulder Screw holes. Insert Shoulder Screw – Torque to 55 inlbs (6Nm). Note that the Shoulder Screw has a thread locking feature which increases the torque required for thread running.

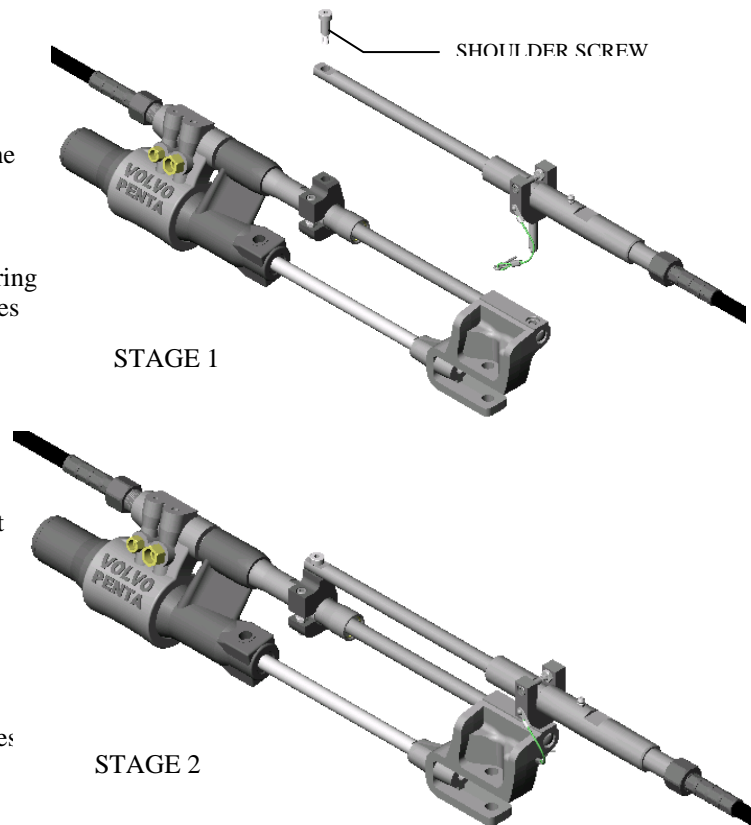

GRAPHIC C2e

**DETAIL INSTALLATION GUIDE (continued)**  
**OC15SUK12B – TYPE B – MULTI I/O CONNECTION KIT**

**C2f. Axially Position Drive Collar and Tighten Clamp Screw**

- i. Using the manual steering helm, set the steering cylinder to mid position as shown. Note that it may be necessary to run the engine to achieve this.
- ii. Axially position Drive Collar to set the 8.25 inches dimension to Yolk (see graphic). Torque Clamp Screw to Drive Collar to 175 inlbs (19Nm). Torque Lock Nut to Drive Collar to 45 inlbs (5Nm).

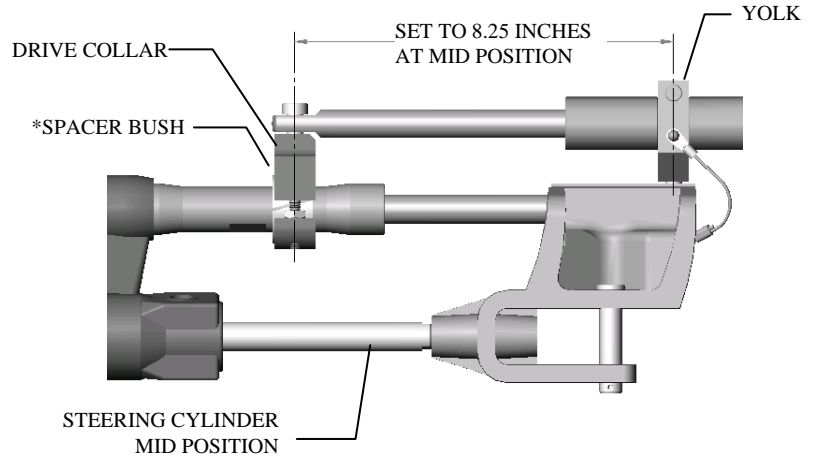

GRAPHIC C2f

- iii. It is recommended that the drive unit is **NOT** attached to the Second Steering Cable when performing operation i. & ii. above. If the drive unit is already attached, it will be **HARDER** to fine adjust the position of the cable rod end. Providing 12v dc power to the clutch and motor circuit may be necessary.

\* Note that the Spacer Bush is not required on models 3862513 & 3862514 which are fitted to drives from September 2003. On these models, the drive collar will clamp directly onto the manual steering cable guide tube.

**C2g. Install Drive Unit**

- i. See separate Detail Installation Guide for Drive Unit.

**C2h. Perform Interference Evaluation (2 people required)**

- i. It is extremely important that a steering system **FULL FUNCTION AND OPERATING CLEARANCE CHECK** be performed between the new Connection Kit & Second Steering Cable and **ALL** adjacent hardware including hoses, electrical cables and control cables.
- ii. The drive unit **MUST** be installed with the Second Steering Cable Assembled before performing the Function & Interference Evaluation. Note that the Guide Tube and Steering Cable Outer Jacket (at the Guide Tube end) **DO MOVE** when the steering system is activated.
- iii. With one person operating the manual steering Helm and one person observing the tiller area. Slowly run the tiller to full HO left and then to full HO right while the observer ensures that there are no physical interferences and that the Steering System is functional. Note that it will be necessary to run the engine to perform this operation.
- iv. It may be necessary to re-rout hoses, electrical cables or control cables. **ALL** hardware must be well clear of the new Connection Kit and Second Steering Cable. Note that chaffing can occur if parts are allowed to come into contact.